

FAM3200

McMenon Metal Variable Area Purgemeter



Armored variable area purgemeters for measuring small flows of gases and liquids

The device is particularly suitable for cloudy, opaque, or aggressive measuring media.

For use in the chemical, petrochemical and pharmaceutical industries, in gas analysis plants, process engineering, well construction and all applications where glass meter tubes cannot be used.

Options

- With needle valve in the inlet / outlet
- Minimum and / or maximum alarm signalling unit
- Analog output 4 to 20 mA
- Differential pressure regulator
- Stainless steel housing

Overview

Model	FAM3220, FAM3250	FAM3225, FAM3255
	Horizontal process connection	Vertical process connection
		
Measured error in accordance with VDE / VDI		
3513	6 % qg = 50 %	6 % qg = 50 %
Repeatability	±0.5 % of the measured value	±0.5 % of the measured value
Process connection	NPT female thread	NPT or pipe female thread
Nominal connection diameters	¼ in NPT	¼ to 1 in NPT, G ¼ to G 1 in
Maximum measuring medium temperature	-50 to 180 °C (-58 to 356 °F)	-50 to 180 °C (-58 to 356 °F)
Maximum pressure rating	PN 40 (other ratings available on request)	PN 100 (other ratings available on request)
Wetted material	Stainless steel 1.4571 (316Ti), Viton A®, Buna N®, Kalrez®, PVDF, PTFE	
Needle valve	In inlet or outlet	-
Indicator / transmitter		
IP degree of protection in accordance with EN 60529	IP 64	
Mechanical indicator / transmitter	Analog indicator with or without alarm signalling unit (FAM3220 / FAM3225)	
Power supply	Analog indicator with transmitter 4 to 20 mA (FAM3250 / FAM3255) Without alarm signalling unit: no power supply Analog indicator with alarm signalling unit: 8 V DC via switching amplifier Analog indicator with transmitter: 10 to 30 V DC, Loop powered	
Indicator housing material	Housing cover: Polycarbonate or stainless steel with fiberglass window Base and cover plate: Anodized aluminum, stainless steel available as an option	

Functional description

The flowmeters in the FAM3200 work according to the float principle.

The position of the float in the conical meter tube is proportional to the flow.

A magnet in the float translates the height of the float as a measurement for the flow to the decouple-proof magnet follower system of the flowmeter.

The flow rate value is indicated on a scale by a pointer mounted on a rotating shaft.

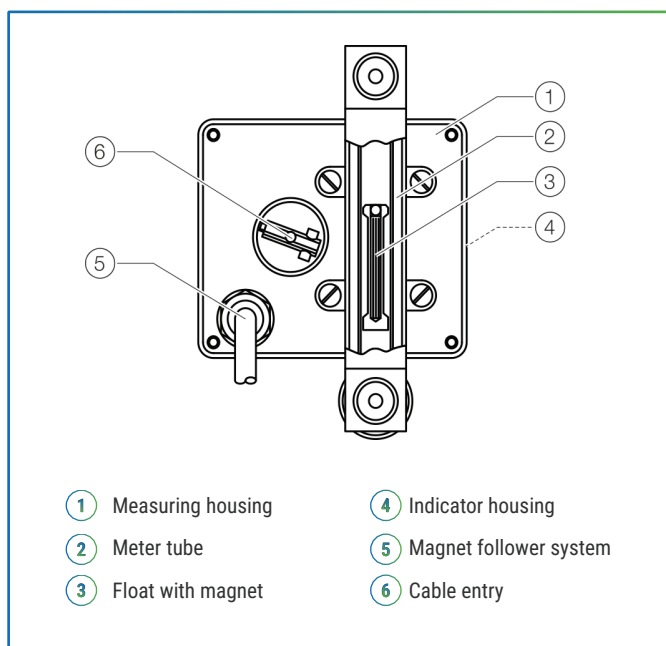

Figure 1: Setup (example)

The devices are used for local indication of the current flow rate with integrated alarm signalling units as flow rate monitors or with differential pressure regulators.

The devices are also optionally available with an angular position transmitter with a 4 to 20 mA output signal.

Introduction and basics

Installation conditions

General

The following points are to be considered during installation:

- The metal cone variable area flowmeter is installed vertically in a piping. The measuring media must flow from bottom to top.
- Keep the device as far away as possible from pipe vibrations. Fastening the piping is normally sufficient.
- Keep the device as far away as possible from powerful magnetic fields. Magnetic fields that are required for operating reasons must not influence the measurement result.
- The nominal diameter of the piping should be the same as the connection nominal diameter.
- Inlet and outlet sections are not required. Valves and pipe bends can be screwed on directly.
- Avoid pulsating flows and sudden pressure surges.
- Use valves which open slowly.
- If the flowmeter is installed in a pipeline where decommissioning is impossible or inexpedient, a bypass line should be provided.
- For gaseous measuring media, the flowmeter should be installed as close as possible to the pipe constrictions. The nominal diameter of the piping at the outlet of the flowmeter should be measured as small as possible.
- Stop and throttle valves should preferably be attached to the outlet of the flowmeter.
- For liquid measuring media, the nominal diameter of the piping should be dimensioned as large as possible (if economically viable).

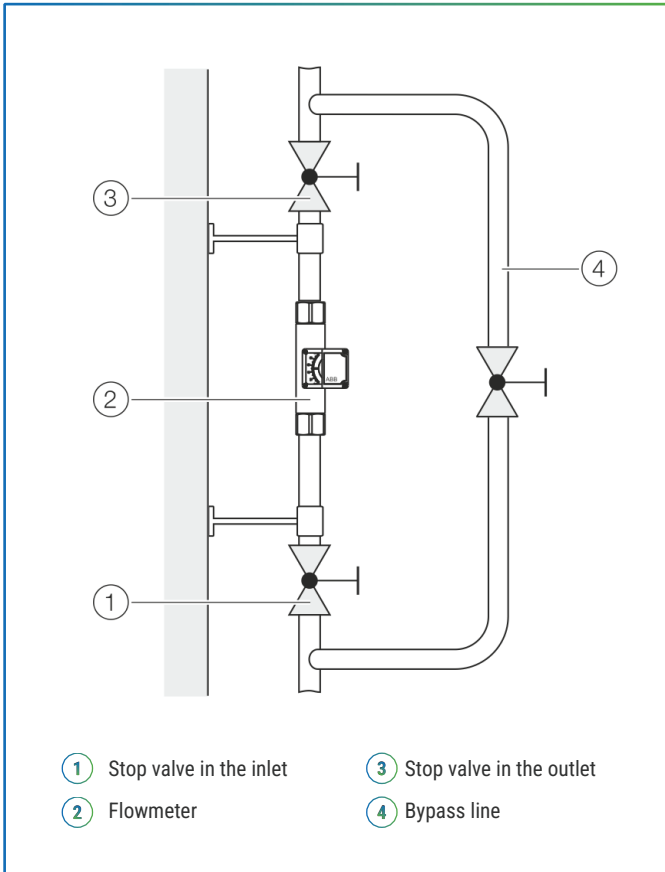

Figure 2: Installation of the flowmeter

Installation recommendations

Refer to VDI / VDE Directive 3513 sheet 3, Selection and Installation Recommendations for Variable Area Flowmeters.

Pressure chambers and collecting tanks

If piston pumps or compressors are used for the transport of the measuring media, a pulsating flow of the measurement media must be expected.

In order to reduce the pulsating of the float, the installation of pressure chambers or collecting tanks in the piping before the flowmeter is recommended.

Sensor insulation

If the flowmeter needs to be insulated, only the meter tube must be included in the pipe insulation. The indicator housing must not be insulated.

This prevents the temperature in the device from rising beyond permitted limits.

Heat tracing

Trace heating may be used under the following conditions:

- The heat tracing must be installed such to make sure that there are no temperature increases in the indicator housing.
- The maximum permitted temperature of the heat tracing must not up-scale the permitted measuring medium temperature.
- When using electrical heat tracing, attention must be paid to potential functional impairment by electromagnetic fields.

Operating conditions

A variable area flowmeter is specified for a defined set of operating conditions of the measuring medium. For liquids and gases, these are pressure and temperature-related properties (density and viscosity) under operating conditions.

For gases, in particular, this means operating at a specific operating pressure and operating temperature. The specified accuracy of the device always refers to the operating conditions underlying the specification.

Pressure loss

The available operating pressure at the measuring point must be higher than the pressure loss listed for the flowmeter in the specifications.

It is important to also consider the pressure loss downstream from the flowmeter due to losses in the piping and other fittings.

For information on pressure loss of the devices, see **Measuring range table** on page 11.

Prevention of compression oscillations when measuring gases

During low flow amounts and low operating pressure, so - called compression oscillations of the float can occur.

If the maximum upstream pressure listed in the specifications is not reached, the flowmeter can optionally be equipped with a mechanical float damper.

Damping is available for the device types FAM3225 and FAM3255 with a process connection size $> \frac{1}{4}$ in.

To prevent self-generated compression oscillations, note the following information from VDI / VDE 3513 Sheet 3:

- Select a flowmeter with the lowest possible pressure loss.
- Minimize the piping length between the flowmeter and the nearest upstream or downstream throttling location.
- Set the limit of the regular measuring range from the usual 10 to 100 % to 25 to 100 %.
- When setting the flow rate value, always start by assuming larger values.
- Increase the operating pressure and consider its effect on the flow rate changes due to the change in gas density in the operating conditions.
- Minimize non-throttled, free volumes upstream and downstream of the device.

Pressure shocks

Especially when measuring gases, it is possible that pressure or shock waves can occur when fast opening solenoid valves are employed and the piping cross-sections are not throttled, or if there are gas bubbles in liquids.

As a result of the sudden expansion of the gas in the piping, the float is forcibly driven against the upper floatstop.

Under certain conditions, this can lead to destruction of the device.

The mechanical float damping is not suitable for the compensation of pressure shocks!

Solids content in the measuring medium

Variable area flowmeters have only limited suitability for measuring media containing solids.

Depending on the concentration, particle size and type of solid, increased mechanical abrasion may occur, especially at the critical measuring edge of the float.

In addition, solidified deposits on the float can change its weight and shape.

These effects can lead to erroneous measurement results, depending on the float type.

In general, the use of appropriate filters is recommended in such applications.

For the flow measurement of measuring media containing magnetic particles, we recommend the installation of a magnetic separator upstream of the variable area flowmeter.

Specification

Scale

Design optionally with percentage scale or product scale. Scale length: Quadrant 60 mm (2.36 in)

Mechanical float damper

Optional with FAM3225 / FAM3255 ¼ in and up to prevent compression oscillations in gas measurements with a low operating pressure.

Measuring accuracy

6 % qg = 50 % in accordance with VDE / VDI 3513, sheet 2

Repeatability

±0.5 % of final value

Measuring range limits and span limits

Measuring span: 1:10

For gas applications up to 3200 l/h air, less than 1:10 For detailed information about measuring ranges, see **Measuring range table** on page 11.

Temperature limits

Maximum permissible ambient temperature:

- Standard design: -10 to 80 °C (14 to 176 °F)
- Low temperature design: -50 to 80 °C (-58 to 176°F)

For devices with alarm signalling units, observe the temperature data in **Alarm signaling unit** on page 9!

IP rating

IP 64

Materials

Materials for wetted parts

Component	Material
Variable area	Stainless Steel 316/316 (1.4401/1.4404) or 316Ti (1.4571)
Orifice plate / cone	Stainless Steel 316/316 (1.4401/1.4404) or 316Ti (1.4571)
O-rings	Viton A®, Buna N®, Kalrez®, EPDM
Fittings	Stainless Steel 316/316 (1.4401/1.4404) or 316Ti (1.4571)
Meter tube holder	PVDF or PTFE (only for device connection ¼ in)

Materials for the indicator housing

Component	Material
Case cover	Polycarbonate or stainless steel with fiberglass window
Base plate	Anodized aluminum Option: stainless steel
Protective cap	Anodized aluminum Option: stainless steel

Material load

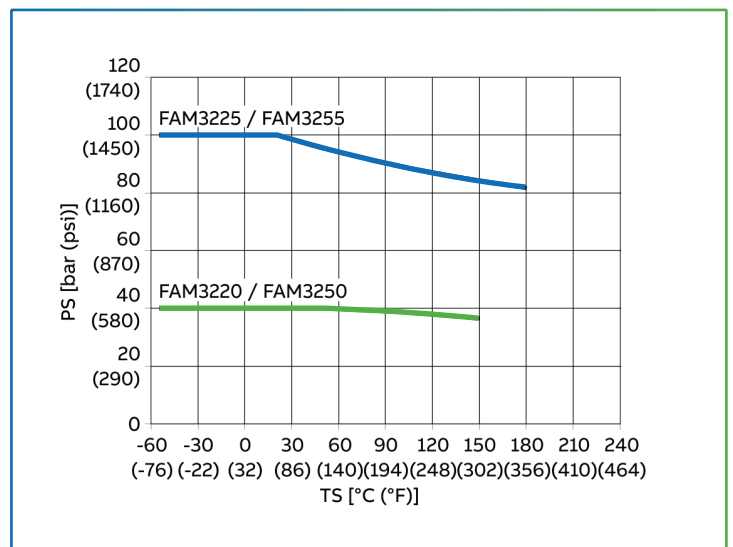

Figure 3: PS: pressure, TS: temperature

...Specification

Maximum permissible operating pressure
The permissible operating pressure is dependent on the optional device equipment.

Model	Option	Maxpermissible operating pressure
FAM3225 / FAM3255	Without	100 bar (1450.38 psi)
FAM3220 /	With needle valve	40 bar (580.15 psi)
FAM3250	With differential pressure regulator	14 bar (203.05 psi) (Standard, higher pressures available on request)

Permissible measuring medium temperature.
Permissible measuring medium temperature depending on gasket material.

Gasket materials

O-ring / meter tube holder	T _{medium} min / max
Viton A® / PVDF	-20 to 100 °C (-4 to 212 °F)
Buna N® / PVDF	-30 to 100 °C (-22 to 212 °F)
Kalrez® / PTFE	0 to 180 °C (32 to 356 °F)
Viton A / PTFE	-20 to 180 °C (-4 to 356 °F)
Buna N / PTFE	-20 to 100 °C (-4 to 212 °F)
EPDM / PVDF	-50 to 100 °C (-58 to 212 °F)
Viton / none	-20 to 180 °C (-4 to 356 °F)
Buna N / none	30 to 100 °C (-22 to 212 °F)
Kalrez / none	0 to 180 °C (32 to 356 °F)

Note

The permissible measuring medium temperature range is dependent on which gasket material is used.

The details on the factory and name plate of the flowmeter must be strictly observed.

Failure to comply with this information can result in destruction of the gasket and the flowmeter.

Analog indicator with or without alarm signaling unit

A magnet in the float translates the height of the float as a measurement for the flow to the decouple-proof magnet follower system of the flowmeter, which is directly connected to the indicator pin.

For analog indicators, the flow value is shown by the indicator on the scale. For analog indicators with an angular position transmitter, the indicator position is also measured directly at the axis.

The optional alarm signalling units can be integrated into the flowmeter housing.

The alarm signalling units are available as single (minimum or maximum alarm) or double alarms (minimum and maximum alarm).

The switching points are adjustable.

The alarm signalling units can be used for switching pumps, solenoid valves, etc.

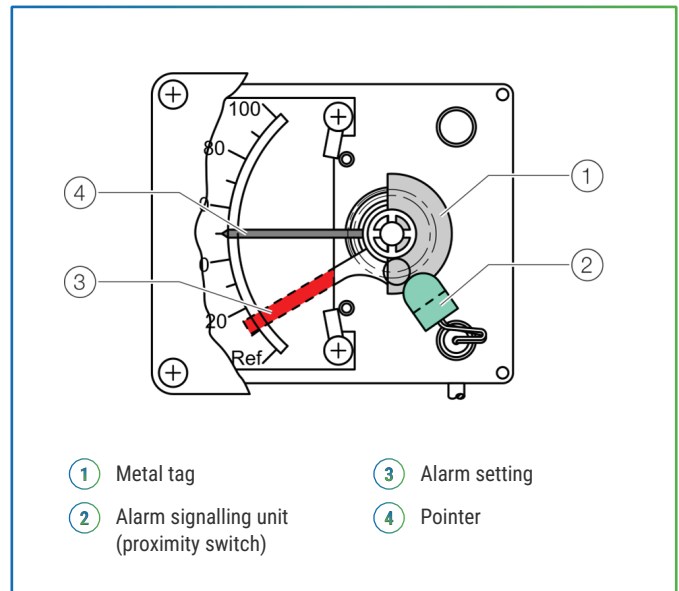

Figure 4: Single alarm (example)

Alarm signaling unit

Specifications	
Operating mode	bistable
Switching function	NAMUR contact
Nominal voltage	8 V DC (Ri approx. 1 kΩ)
Operating voltage	5 to 25 V DC
Switching frequency	Maximum 5 kHz
Connection type	Cable, 2-wire, brown (+) / white (-), length 1.75 m (5.74 ft)*
Switching point single alarm	Minimum 0 to 60 % Maximum 40 to 100 %
Switching point double alarm	Minimum setting range approx. 5 %
Setting accuracy	±2 % of measured value
Repeatability	±0.5% of scale end value

* Other cable lengths available on request.

Temperature and electrical data

The following table shows the maximum permitted measuring medium temperature T_{medium} and the permitted electrical data depending on the ambient temperature T_{ambient} and the gasket material.

Ambient temperature T_{ambient}							
40 °C (104 °F) 50 °C (122 °F) 60 °C (140 °F)							
System bus, computer interfaces		T_{medium} maximum [°C (°F)]					
I_i [mA]	P_i [mW]	A	B	A	B	A	B
25	34	100 (212)	180 (356)	100 (212)	165 (329)	100 (212)	155 (311)
25	64	100 (212)	180 (356)	100 (212)	165 (329)	100 (212)	155 (311)
52	169	100 (212)	130 (266)	100 (212)	115 (239)	100 (212)	100 (212)
76	242	80 (176)	80 (176)	65 (149)	65 (149)	50 (122)	50 (122)

Switching amplifier

A switching amplifier is needed to operate the alarm signaling units. See Ordering information switching amplifier on page 23 for further information.

Specifications	
Power supply	230 V AC, +10 % / -15 %, 45 to 60 Hz 115 V AC, +10 % / -15 %, 45 to 60 Hz 24 V DC, +10 % / -15 %
Output	One or two switching relays with potential-free changeover contacts
Switching capacity	Maximum 250 V, maximum 4 A, maximum 500 VA
Maximum permissible cable length	Between the switching amplifier and alarm signalling unit: 300 m (984 ft)
Permissible ambient temperature range	-10 to 60 °C (14 to 140 °F)
Electrical connection	Screw terminals, maximum 2.5 mm ² (14 AWG)
Type of assembly	35 mm top-hat rail in accordance with EN 60715:2001
IP rating	IP 20 in accordance with EN 60529
Weight	approx. 150 g (0.3 lb)

Analog Indicator with Transmitter

The models FAM3250 / FAM3255 have an integrated angular position transmitter.

The angular position transmitter is installed on the indicator axis of the analog indicator and transforms the indicator position into a 4 to 20 mA output signal proportional to the measured value.



Figure 5: Flowmeter with angular position transmitter (example)

Differential Pressure Regulator

The optional differential pressure regulator is used in connection with the flowmeter.

The differential pressure regulator has the task of halting the flow that is adjusted using the needle valve of the purgometer.



Figure 6: Flowmeter with differential pressure regulator

Maximum permissible operating pressure
14 bar (203 psi)

Maximum permissible differential pressure
7 bar (101.5 psi)

Required upstream pressure
≥ 0.2 bar

Maximum flow rate
Water: approx. 75 l/h Air: Qn approx. 2000 l/h

Weight
1.2 kg (2.5 lb) including flowmeter

Materials

Component	Material
Housing	Stainless steel 1.4571
Diaphragms	Viton A®* (maximum 180 °C (356 °F))
O-rings	Viton A®*
Springs	Stainless steel 1.4401
Valve seat and pin	Stainless steel 1.4401
Connecting pipe	Stainless steel 1.4301
Pipe fitting	Stainless steel 1.4301

* For ammonia, Buna N® is required (maximum 120 °C (248 °F))

Specifications

Output signal	4 to 20 mA, two-wire technology
Power supply	maximum 30 V DC
Input Current	maximum 30 mA
Connection type	Cable, 2-wire, brown (+) / white (-), length 1.75 m (5.74 ft)*
Ambient temperature range	-10 to 40 °C (14 to 104 °F)
Design	Angular position transmitter in two - wire technology

* Other cable lengths available on request.

Measuring Range Table

Models FAM3220 / FAM3250 / FAM3225 / FAM3255, variable area and metal cone

The data listed applies for water at 20 °C (68 °F), 1 kg/dm³ (62.43 lb/ft³), 1 mPas (1 cP) and for air at 0 °C (32 °F), 1013 mbar (14.7 psia).

Process connection ¹	Maximum flowrate		V _{std} ² (mPas [cp])	P _{dif} ³ (bar [psil])	P _{sta} ⁴ (bar [psil])	D _p ⁵ (mbar [psil])	Order code ⁶
	Water (l/h [USgal/h])	Air (l/h [scfh])					
¼ in	1 (0.26)	35 (1.24)	4 (4)	0.7 (10.15)	1.0 (14.5)	8 (0.12)	01H
	1.6 (0.42)	54 (1.91)	4 (4)	0.7 (10.15)	1.0 (14.5)	8 (0.12)	02H
	2.5 (0.66)	100 (3.53)	6 (6)	0.7 (10.15)	1.0 (14.5)	8 (0.12)	03H
	4 (1.06)	160 (5.65)	6 (6)	0.7 (10.15)	1.0 (14.5)	8 (0.12)	04H
	6 (1.59)	230 (8.12)	18 (18)	0.7 (10.15)	1.0 (14.5)	8 (0.12)	05H
	10 (2.64)	350 (12.36)	18 (18)	0.7 (10.15)	1.0 (14.5)	8 (0.12)	06H
	16 (4.23)	540 (19.07)	18 (18)	0.7 (10.15)	1.0 (14.5)	8 (0.12)	07H
	25 (6.6)	850 (30.02)	18 (18)	0.7 (10.15)	1.0 (14.5)	9 (0.13)	08H
	40 (10.57)	1250 (44.14)	18 (18)	0.7 (10.15)	1.0 (14.5)	10.5 (0.15)	09H
	60 (15.85)	1900 (67.1)	18 (18)	0.7 (10.15)	1.0 (14.5)	12.5 (0.18)	10H
100 (26.42)	3100 (109.48)	12 (12)	-7	1.0 (14.5)	17.0 (0.25)	11H	

1. Connection nominal diameter.
2. V_{std}: Maximum permissible viscosity without calibration.
3. P_{dif}: Minimum required differential pressure for operation with a differential pressure regulator (FAM3220 / FAM3250 only).
4. P_{sta}: Minimum required static pressure to prevent compression oscillations. For lower pressures, consult McMenon.
5. Total pressure loss with stainless steel float at maximum flow.
6. Order code of the meter tube-float combination. See **Ordering Information** on page 18 for further information.
7. Not available with differential pressure regulator.

... Specification

Model FAM3225 / FAM3255, conical float and orifice

The data listed applies to water at 20 °C (68 °F), 1 kg/dm³ (62.43 lb/ft³), 1 mPas (1 cP) and to air at 0 °C (32 °F), 1013 mbar (14.7 psia).

Process connection ¹	Maximum flowrate		Vstd ² (mPas [cpl])	Pdif ³ (bar [psil])	Psta ⁴ (bar [psil])	Dp ⁵ (mbar [psil])	Order code ⁶
	Water (l/h [USgal/h])	Air (l/h [scfh])					
¾ in or ½ in	100 (26.42)	3200 (113.01)	8 (8)	4.0 (58.02)	0.3 (4.35)	60 (0.87)	20H
	160 (42.27)	5000 (176.57)	8 (8)	4.0 (58.02)	0.3 (4.35)	70 (1.02)	21H
	200 (52.83)	6000 (211.89)	8 (8)	4.0 (58.02)	0.3 (4.35)	80 (1.16)	22H
	250 (66.04)	8000 (282.52)	8 (8)	4.0 (58.02)	0.3 (4.35)	90 (1.31)	23H
	300 (79.25)	9000 (317.83)	8 (8)	4.0 (58.02)	0.3 (4.35)	160 (2.32)	24H
½ in	400 (105.67)	12000 (423.78)	8 (8)	4.0 (58.02)	0.3 (4.35)	75 (1.09)	30H
	500 (132.09)	15000 (529.72)	8 (8)	4.0 (58.02)	0.3 (4.35)	85 (1.23)	31H
	600 (158.5)	18000 (635.66)	8 (8)	4.0 (58.02)	0.3 (4.35)	95 (1.38)	32H
	700 (184.92)	21000 (5547.61)	8 (8)	4.0 (58.02)	0.3 (4.35)	105 (1.53)	33H
	800 (211.34)	24000 (847.55)	8 (8)	4.0 (58.02)	0.3 (4.35)	130 (1.89)	34H
1 in	800 (211.34)	23800 (840.49)	3 (3)	16 (232.06)	0.4 (5.8)	60 (0.87)	40H
	1000 (264.17)	29700 (1048.85)	3 (3)	16 (232.06)	0.4 (5.8)	62 (0.9)	41H
	1600 (422.68)	47600 (1680.98)	3 (3)	16 (232.06)	0.4 (5.8)	74 (1.07)	42H
	2000 (528.34)	59500 (2101.22)	3 (3)	16 (232.06)	0.4 (5.8)	85 (1.23)	43H
	2500 (660.43)	74400 (2627.41)	3 (3)	16 (232.06)	0.4 (5.8)	105 (1.52)	44H
	3000 (792.52)	89300 (3153.6)	3 (3)	16 (232.06)	0.4 (5.8)	130 (1.89)	45H

1. Connection nominal diameter.
2. Vstd: Maximum permissible viscosity without calibration.
3. Psta: Minimum required static pressure to prevent compression oscillations. At low pressure, the use of the float damper is required.
4. Pmin: Minimum required static pressure in the device when using the optional float damper (Wendel).
5. Total pressure loss with stainless steel float at maximum flow.
6. Order code of the meter tube-float combination. See **Ordering Information** on page 18 for further information.

Dimensions

Model FAM3220 / FAM3225

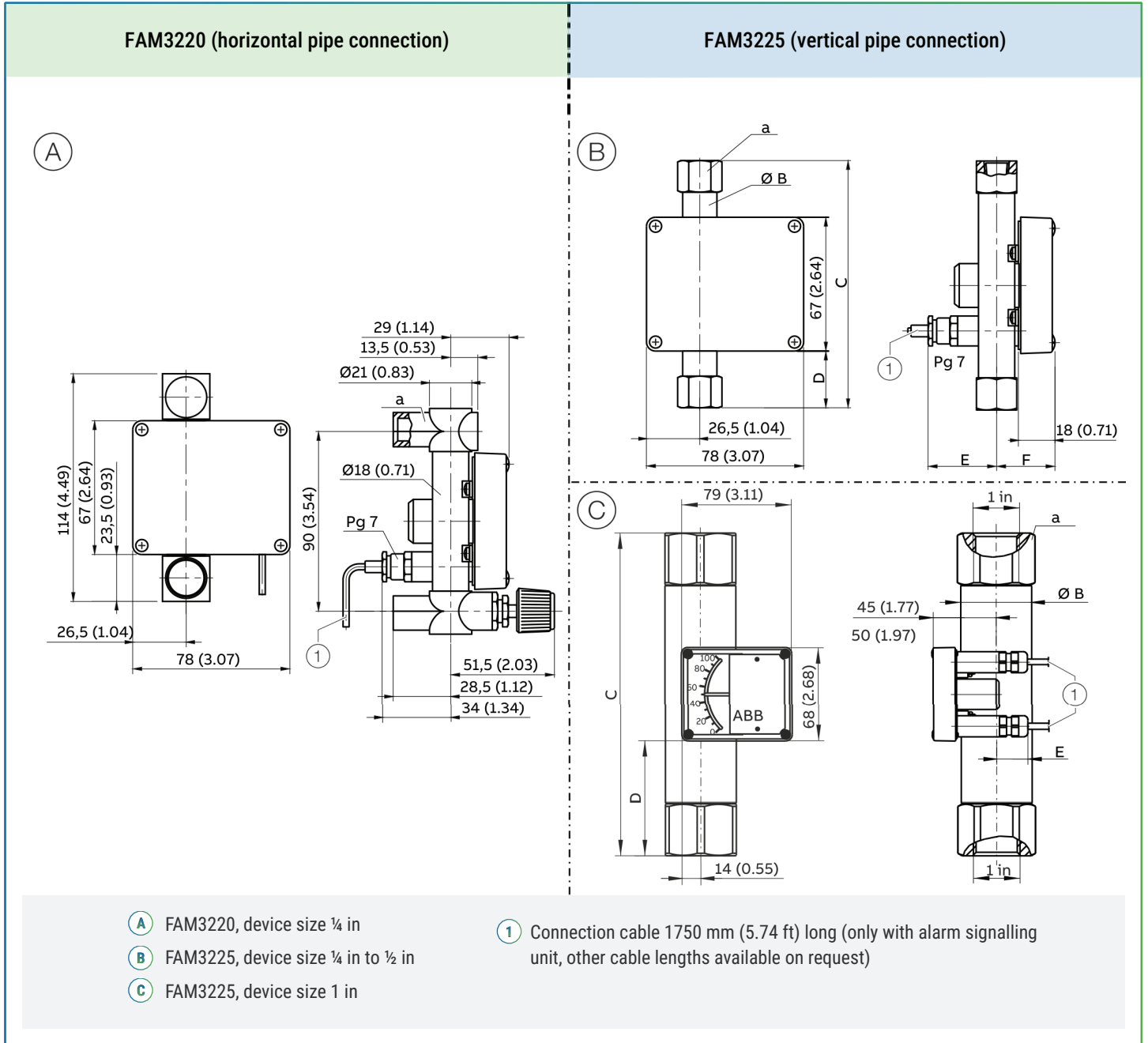

Figure 7: Dimensions in mm (in), projection in accordance with ISO method E, SW width across flats in mm

Model	Meter size	Ø a	Ø B (mm [in])	Ø C (mm [in])	Ø D (mm [in])	Ø E (mm [in])	Ø F (mm [in])	Weight (kg [lb])
FAM3220	¼ in	SW22	18 (0.71)	125 (4.92)	29 (1.14)	34 (1.34)	29 (1.14)	0.4 (0.88)
FAM3225	¼ in	SW19						0.3 (0.66)
FAM3225	⅜ in	SW24	25 (0.98)	164 (6.46)	48.5 (1.91)	30.5 (1.2)	32.5 (1.28)	0.5 (1.1)
FAM3225	½ in	SW27	25 (0.98)	164 (6.46)	48.5 (1.91)	30.5 (1.2)	32.5 (1.28)	0.6 (1.32)
FAM3225	1 in	SW50	50 (1.97)	230 (9.06)	81 (3.19)	18 (0.71)	–	2.2 (4.85)

...Dimensions

Model FAM3250 / FAM3255

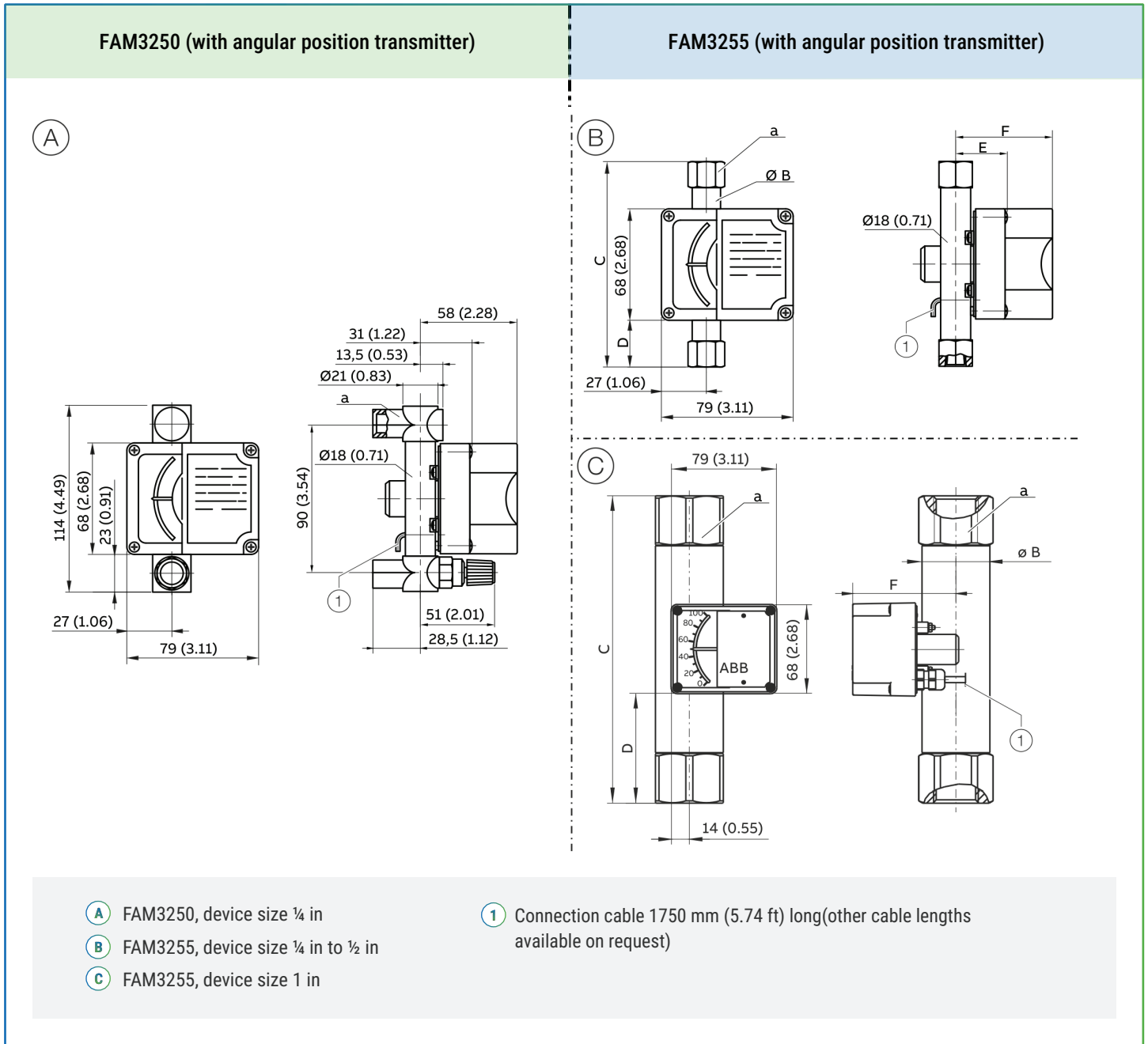

Figure 8: Dimensions in mm (in), projection in accordance with ISO method E, SW width across flats in mm

Model	Meter size	a	Ø B (mm [in])	Ø C (mm [in])	Ø D (mm [in])	Ø E (mm [in])	Ø F (mm [in])	Weight (kg [lb])
FAM3250	¼ in	SW22	18 (0.71)	125 (4.92)	29 (1.14)	31 (1.22)	58 (2.28)	0.5 (1.1)
FAM3255	¼ in	SW19	18 (0.71)	125 (4.92)	29 (1.14)	31 (1.22)	58 (2.28)	0.4 (0.88)
FAM3255	⅜ in	SW24	25 (0.98)	164 (6.46)	48.5 (1.91)	34.5 (1.36)	61.5 (2.42)	0.6 (1.32)
FAM3255	½ in	SW27	25 (0.98)	164 (6.46)	48.5 (1.91)	34.5 (1.36)	61.5 (2.42)	0.7 (1.54)
FAM3255	1 in	SW50	50 (1.97)	230 (9.06)	81 (3.19)	—	74 (2.91)	2.3 (5.07)

...Dimensions

Model FAM3220 / FAM3250, with differential pressure regulator for wall mounting

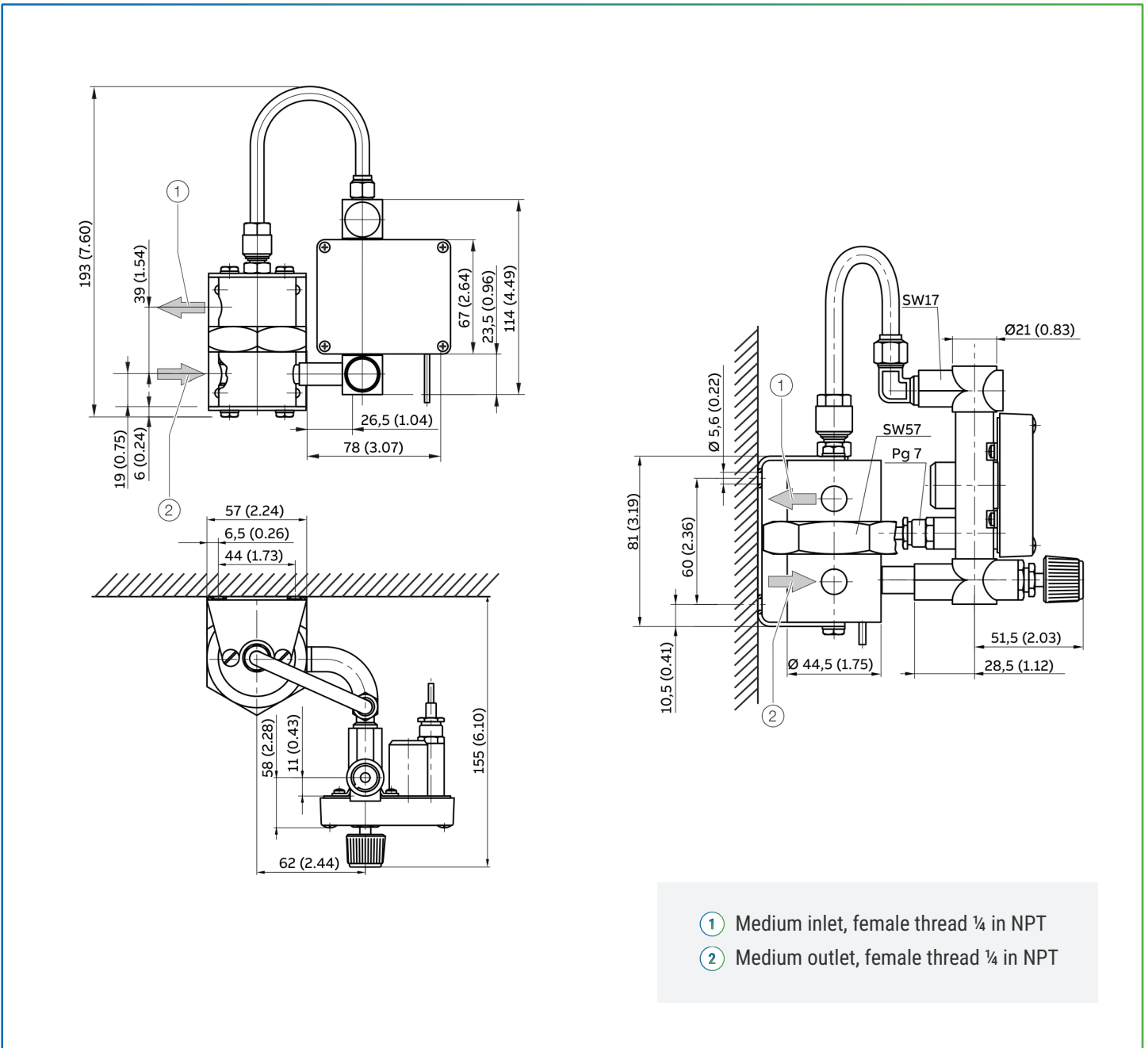

Figure 9: Dimensions in mm (in), projection in accordance with ISO method E

...Dimensions

Model FAM3220 / FAM3250, with differential pressure regulator for cable assembly

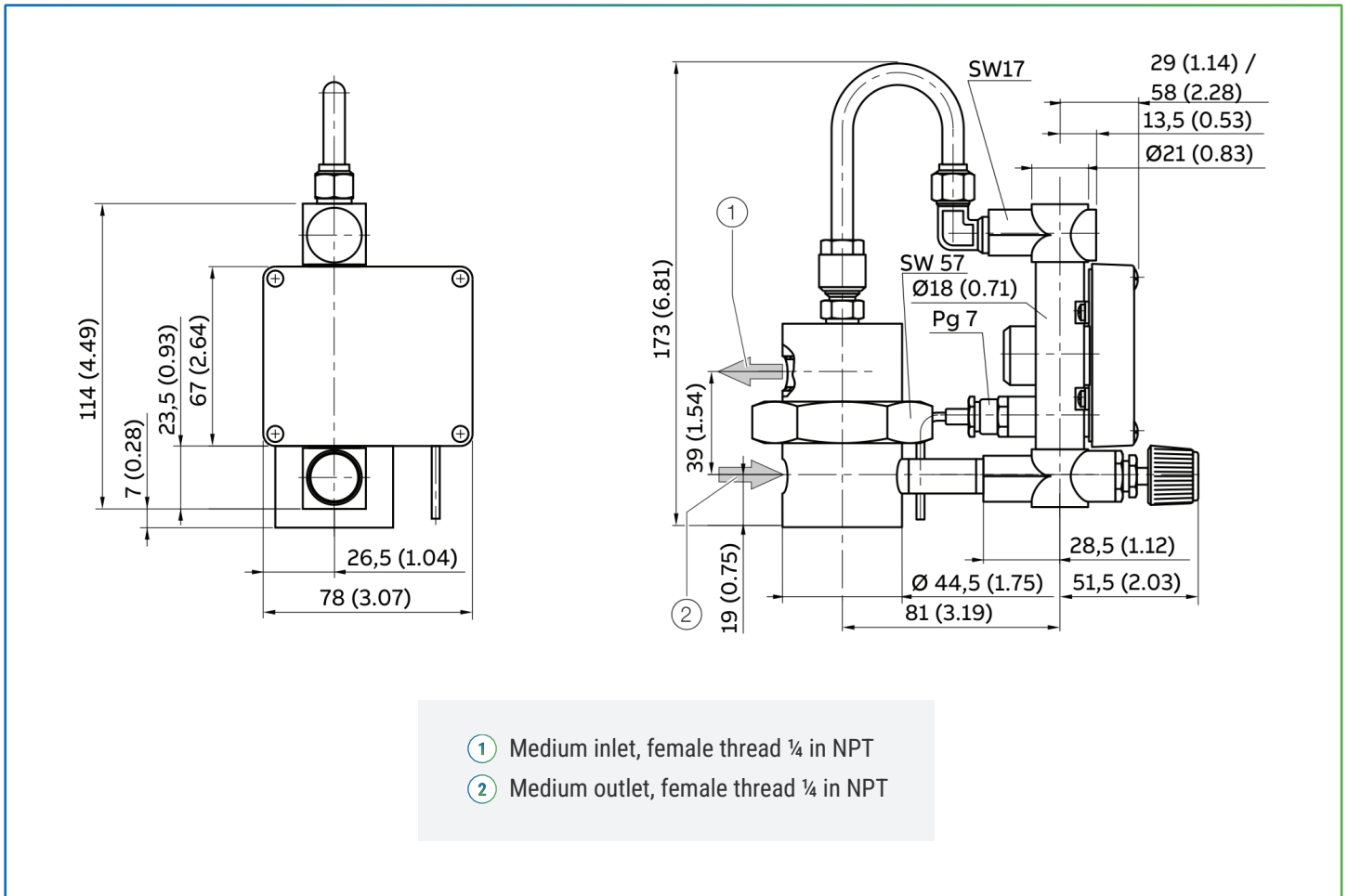

Figure 10: Dimensions in mm (in), projection in accordance with ISO method E

Accessories

Needle Valves

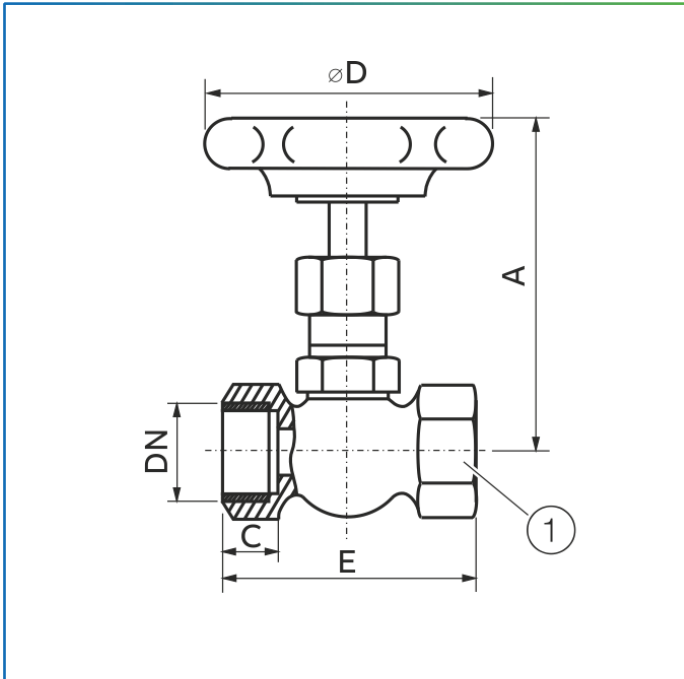

Figure 11: Brass needle valve

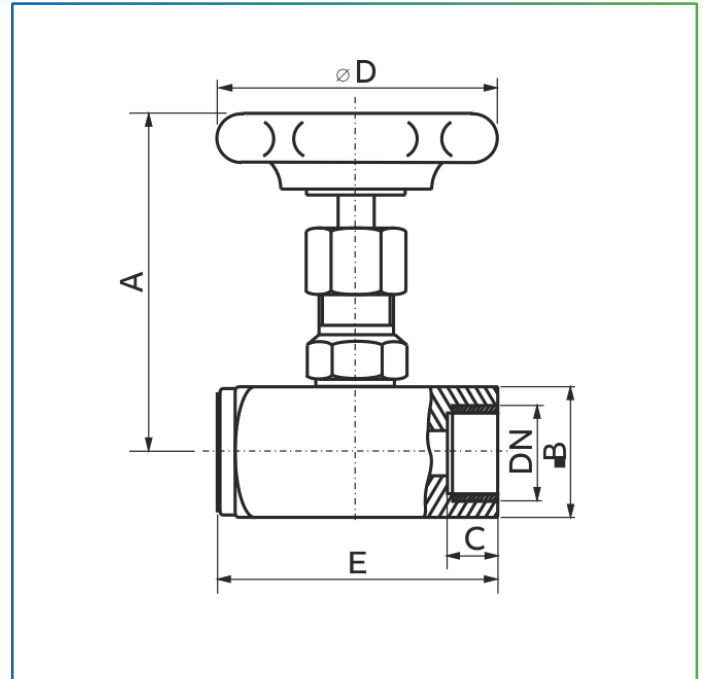

Figure 12: Stainless steel needle valve

Needle valves for installation in the piping before or after the flowmeter. Valves in the in-line housing with female thread connections. For ordering information, see **Ordering information needle valves** on page 23.

Drawing	Material	Pressure rating	Temperature
Figure 11	Brass	PN 100	maximum 100 °C (212 °F)
Figure 12	Stainless steel 1.4571 (AISI 316Ti)	PN 200	maximum 180 °C (356 °F)

Brass needle valve Figure 11

DN	$\varnothing D$ mm (in)	A mm (in)	C mm (in)	E mm (in)	Width across flats mm
G ¼ in	50 (1.97)	72 (2.83)	10 (0.39)	50 (1.97)	22
G ½ in	63 (2.48)	72 (2.83)	12 (0.47)	55 (2.17)	25
G ¾ in	63 (2.48)	95 (3.74)	14 (0.55)	67 (2.64)	32
G 1 in	90 (3.54)	130 (5.12)	17 (0.67)	74.5 (2.93)	40

Stainless steel needle valve Figure 12

DN	$\varnothing D$ mm (in)	A mm (in)	B mm (in)	C mm (in)	E mm (in)
G ¼ in	50 (1.97)	72 (2.83)	25 (0.98)	13 (0.51)	50 (1.97)
G ½ in	63 (2.48)	72 (2.83)	30 (1.18)	16 (0.63)	60 (2.36)
G ¾ in	63 (2.48)	95 (3.74)	35 (1.38)	18 (0.71)	75 (2.95)
G 1 in	90 (3.54)	130 (5.12)	45 (1.77)	22 (0.87)	100 (3.94)
¼ in NPT	50 (1.97)	72 (2.83)	25 (0.98)	13 (0.51)	50 (1.97)
¾ in NPT	50 (1.97)	72 (2.83)	25 (0.98)	13 (0.51)	55 (2.17)
½ in NPT	63 (2.48)	72 (2.83)	30 (1.18)	16 (0.63)	60 (2.36)

Ordering Information

FAM3220 and FAM3250

FAM3220: Analog indicator with / without alarm, horizontal screw connection

FAM3250: Analog indicator with angular position transmitter, horizontal screw connection

FAM3200 Armored Variable Area Purgemeter	X	X	XX	X	X	X	X	X	X	X	X	X	X	X	X	X	
Secondary																	
Indicator	2*																
Indicator with electronic converter	5**																
Meter Construction																	
Fitting design (horizontal)	0																
Design Level (Specified by McMenon)																	
			XX														
Needle Valve Position																	
Without valve				A													
Inlet fitting				N													
Outlet fitting				M													
Material of Adapter / Sealing																	
PVDF / Viton A (¼ in)																1	
PVDF / Buna N (¼ in)																2	
PTFE / Kalrez (¼ in)																3	
PTFE / Viton A (¼ in)																7	
PVDF / EPDM (¼ in) (Low Temperature -50 °C)																A	
Fitting Material																	
Stainless Steel 316/316L(1.4401/1.4404) or 316T1 (1.4571)																	T
Tube Material																	
Stainless Steel 316/316L(1.4401/1.4404) or 316T1 (1.4571)																	T
Certificates																	
Standard																	A
Inspection certificate 3.1 acc. EN 10204																	B
Pressure test acc. AD2000																	C
Material certificate 3.1 acc. EN 10204 with pressure test acc. AD2000																	D
Float Construction																	
Standard, without twisted guide rod																	0
Housing																	
Polycarbonate																	A*
Frame AISI 316Ti SST (1.4571), glass window																	C*
Frame AISI 316Ti SST (1.4571), glass window + base plate and cover AISI 316Ti SST (1.4571)																	E*

* Only with FAM3220

** Only with FAM3250

Continued see next page...

FAM3200 Armored Variable Area Purgemeter	X	X	X	X	X
Signal Output					
Indicator without output signal	0*				
Indicator with Min. Alarm	1*				
Indicator with Max. Alarm	2*				
Indicator with Min. / Max. Alarm	3*				
Indicator with analog output 4 to 20 mA / 2-wire (not for Ex)	4**				
Differential Regulator					
Without		A			
Model 53RT2110, AISI 316Ti SST (1.4571)		T***			
Mounting					
Inline mounting			1		
Wall mounting (only with differential pressure regulator)			2		
Connection Type					
¼ in NPT				A	
Name Plate					
McMenon Standard					1
Explosion Protection Certification and Approvals					
Without					Y0
ATEX Zone 2 *#					B1

- * Only with FAM3220
- ** Only with FAM3250
- *** With inlet needle valve only
- # Only with polycarbonate housing

Additional ordering information

FAM3200 Armored Variable Area Purgemeter	XXX	X	X	XXX
Tube / Float Combination				
(Specified by McMenon, for possible order codes, see chapter Measuring range table on page 11)	XXX			
Scale				
Percentage scale		X ²		
Direct reading		X ²		
Connection Type				
Standard			A	
Inspection certificate EN 10204 - 3.1 for calibration with test report			B	
Declaration of compliance for calibration acc. to EN 10204 - 2.1			D	
Special Options				
With 5 m signal cable				W01 ^{1,3}
Ambient temperature -50 to 80 °C				W02 ^{1,4}
With 3 m signal cable				W03 ^{1,3}

1. Only with FAM3220
2. The scale design must be specified when ordering. The relevant order code is defined by McMenon depending on the application.
3. Indicator with Alarm only
4. Indicator without output signal only

...Ordering Information

FAM3225 and FAM3255

FAM3225: Analog indicator with / without alarm, vertical screw connection

FAM3255: Analog indicator with angular position transmitter, vertical screw connection

FAM3200 Armored Variable Area Purgemeter	D10A32	X	X	XX	X	X	X	X	X	X	X	X	X	X	X	X	X
Secondary																	
Indicator		2*															
Indicator with electronic converter		5**															
Meter Construction																	
Fitting design (horizontal)		0															
Design Level (Specified by McMenon)																	
				XX													
Needle Valve Position																	
Without valve					A												
Material of Adapter / Sealing																	
PVDF / Viton A (¼ in)										1							
PVDF / Buna N (¼ in)										2							
PTFE / Kalrez (¼ in)										3							
Without / Viton A (> ¼ in)										4							
Without / Buna N (> ¼ in)										5							
Without / Kalrez (> ¼ in)										6							
PVDF / EPDM (¼ in.) (Low Temperature -50 °C)										A							
Without / EPDM (> ¼ in.) (Low Temperature -50 °C)										B							
Fitting Material																	
AISI 316Ti SST (1.4571)																	T
Tube Material																	
AISI 316Ti SST (1.4571)																	T
Certificates																	
Standard																	A
Inspection certificate 3.1 acc. EN 10204																	B
Pressure test acc. AD2000																	C
Material certificate 3.1 acc. EN 10204 with pressure test acc. AD2000																	D
Float Construction																	
Standard, without twisted guide rod																	0
With twisted rod (> ¼ in)																	1
Housing																	
Polycarbonate																	A*
Frame AISI 316Ti SST (1.4571), window of glass																	C*
Frame AISI 316Ti SST (1.4571), window of glass + base plate and cover AISI 316Ti SST (1.4571)																	E*

* Only with FAM3225

** Only with FAM3255

Continued see next page...

FAM3200 Armored Variable Area Purgemeter	X	X	X	X	X	
Signal Output						
Indicator without output signal	0*					
Indicator with Min. Alarm	1*					
Indicator with Max. Alarm	2*					
Indicator with Min. / Max. Alarm	3*					
Indicator with analog output 4 to 20 mA / 2-wire (not for Ex)	4**					
Differential Regulator						
Without		A				
Mounting						
Inline mounting			1			
Connection Type						
¼ in NPT (1 to 100 l/h water)						A
G ¼ in (1 to 100 l/h water)						B
¾ in NPT (100 to 300 l/h water)						K
G ¾ in (100 to 300 l/h water)						L
½ in NPT (400 to 800 l/h water)						M
G ½ in (400 to 800 l/h water)						N
1 in NPT (800 to 3000 l/h water)						P
G 1 in (800 to 3000 l/h water)						Q
Male connector 6CM8						S
Name Plate						
McMenon Standard						1
Explosion Protection Certification and Approvals						
Without						Y0

* Only with FAM3225

** Only with FAM3255

Additional ordering information

FAM3200 Armored Variable Area Purgemeter	XXX	X	X	XXX
Tube / Float Combination (Specified by McMenon, for possible order codes, see chapter Measuring range table on page 11)	XXX			
Scale				
Percentage scale		X ²		
Direct reading		X ²		
Connection Type				
Standard			A	
Inspection certificate EN 10204 - 3.1 for calibration with test report			B	
Declaration of compliance for calibration acc. to EN 10204 - 2.1			D	
Special Options				
With 5 m signal cable				W01 ^{1,3}
Ambient temperature -50 to 80 °C				W02 ^{1,4}
With 3 m signal cable				W03 ^{1,3}

1. Only with FAM3220
2. The scale design must be specified when ordering. The relevant order code is defined by McMenon depending on the application.
3. Indicator with Alarm only
4. Indicator without output signal only

Declarations and certificates for FAM3200

Designation
Declaration of compliance in accordance with EN 10204-2.1
Declaration of compliance in accordance with EN 10204-2.2
Test report dye-penetrant technique DIN 54152
Calibration certificate including declaration of compliance for accuracy (not DN 100)
Declaration of compliance for accuracy
Declaration of compliance for visual inspection and dimension check
Certificate in accordance with NACE MR 01-75 (FAM54x, FAM3200) (Contact Factory for more details)

Accessories

Ordering information switching amplifier

Designation	Ordering number
DSwitching amplifier model KFA5-SR2-Ex1.W, single alarm, 115 V AC 50 / 60 Hz	D163A011U01
Switching amplifier model KFA6-SR2-Ex1.W, single alarm, 230 V AC 50 / 60 Hz	D163A011U02
Switching amplifier model KFD2-SR2-Ex1.W, single alarm, 24 V DC	D163A011U03
Switching amplifier model KFA5-SR2-Ex2.W, double alarm, 115 V AC 50 / 60 Hz	D163A011U04
Switching amplifier model KFA6-SR2-Ex2.W, double alarm, 230 V AC 50 / 60 Hz	D163A011U05
Switching amplifier model KFD2-SR2-Ex2.W, double alarm, 24 V DC	D163A011U06

Ordering information needle valves

Designation	Ordering number
Brass Needle Valve	
Needle valve, material brass, G ¼ in, separate	1D125D1004
Needle valve for oxygen applications, material brass, G ¼ in, separate	D125D001U01
Needle valve, material brass, G ½ in, separate	1D125D1005
Needle valve for oxygen applications, material brass, G ½ in, separate	D125D001U02
Needle valve, material brass, G ¾ in, separate	1D125D1006
Needle valve for oxygen applications, material brass G ¾ in, separate	D125D001U03
Needle valve, material brass, G 1 in, separate	1D125D1017
Needle valve for oxygen applications, material brass, G 1 in, separate	D125D001U04
Stainless Steel Needle Valve	
Needle valve, material 1.4571 (AISI 316Ti), G ¼ in, separate	1D125D1001
Needle valve, material 1.4571 (AISI 316Ti), G ½ in, separate	1D125D1002
Needle valve, material 1.4571 (AISI 316Ti), G ¾ in, separate	1D125D1003
Needle valve, material 1.4571 (AISI 316Ti), G 1 in, separate	1D125D1019
Needle valve, material 1.4571 (AISI 316Ti), ¾ in NPT, separate	D125D003U01
Needle valve, material 1.4571 (AISI 316Ti), ¼ in NPT, separate	D125D003U02
Needle valve, material 1.4571 (AISI 316Ti), ½ in NPT, separate	D125D003U03

Trademarks

Buna-N is a registered trademark of DuPont Dow Elastomers.
Kalrez and Kalrez Spectrum are registered trademarks of DuPont Performance Elastomers.
Viton is a DuPont de Nemours trademark



McMenon Engineering Services Ltd
Salterbeck Trading Estate, Workington,
Cumbria, CA14 5DS, UK.

+44 (0)1946 830 611

sales@McMenon.com



www.mcmemon.com

OUR CERTIFICATIONS



Note:

We reserve the right to make technical changes or modify the contents of this document without prior notice. With regard to purchase orders, the agreed particulars shall prevail. MCMENON does not accept any responsibility whatsoever for potential errors or possible lack of information in this document.

We reserve all rights in this document and in the subject matter and illustrations contained therein. Any reproduction, disclosure to third parties or utilization of its contents in whole or in parts – is forbidden without prior written consent of MCMENON.